



## NEW PRODUCT ANNOUNCEMENT

NPA2003-9, June 2003

### GM 4T60E & 4T65E Molded Pan Gasket With 6mm Bolt Holes

In midyear of 1998 General Motors changed the pan bolts used in the 4T60E and 4T65E from an 8mm shank to a 6mm shank. Along with this change, the size of the bolt holes in the molded pan gasket was reduced in diameter.

The 8mm bolt design gasket has been proven to perform competently in place of the 6mm design, and all TransTec kits that currently include a molded pan gasket will continue to contain only the 8mm design gasket.

However, for the discriminating builder who will not deviate from the 6mm design, TransTec is pleased to offer the 6mm design gasket in bulk under part #33212.

TransTec #	Reference #	Application	Years
32542	24204624	4T60E w/8mm bolts	1991-98
		4T65E w/8mm bolts	1997-98
33212	24206182	4T60E w/6mm bolts	1998-99
		4T65E w/6mm bolts	1998-Up

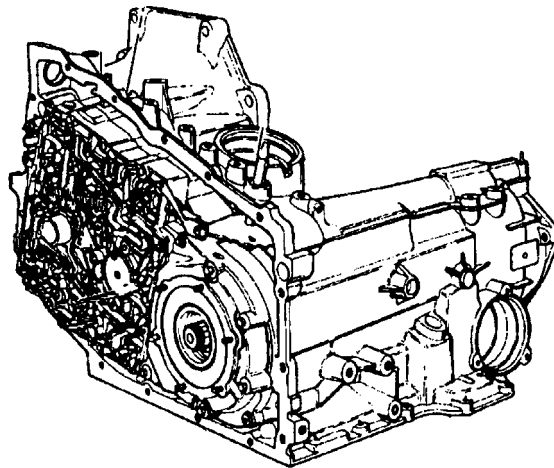

Gasket w/6mm Bolt Holes  
TransTec #33212

