

Ford 4R70/75W & 4R70/75E 2004-up

In the 2004 model year Ford made some changes to the 4R70/75W as well as introducing another version of these units with a designation of 4R70/75E.

Both the "W" and "E" version received new plastic-designed forward clutch rings, solid Teflon rings for the direct clutch and a molded one-piece design intermediate apply piston. The 4R70/75E went on to receive a new turbine shaft sensor.

TransTec is pleased to announce the availability of a new overhaul kit for the 2004-up Ford 4R70/75W and 4R70/75E.

TransTec kit 2478 will include the new plastic design forward clutch rings, solid Teflon direct clutch rings as well as the o-ring to service the new turbine shaft sensor found on the new 4R70/75E models.

This kit is also available with a Duraprene pan gasket under TransTec # **DP2478**.

The bonded intermediate piston will **not** be included in either kit, but is available separately for bulk sales under TransTec # **B82063**.

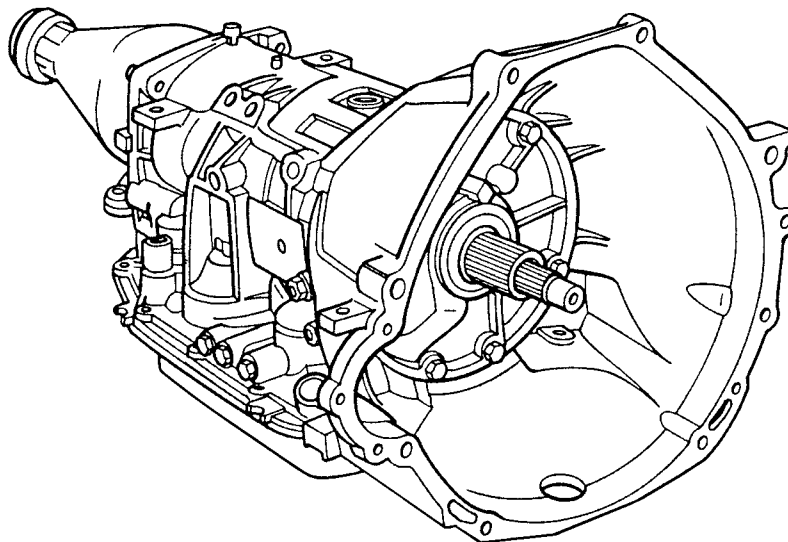

Both kits are in stock and available for immediate delivery!



11617 State Route 13
Milan, Ohio 44846
Phone: 419-499-2502
Fax: 419-499-6099
www.transtec.com
www.corteco-na.com