

TransTechnical **Bulletin**

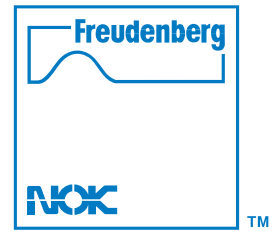

Application: Chrysler 42/44RE
Subject: 2000-Up

Chrysler has released a new direct clutch outer lip seal for the 42 & 44RE transmissions. The drum, piston, and outer seal have all been revised for 2000-Up models. The outer clutch piston seal is now located in the drum rather than on the piston. The inner clutch seal remains in the same place and carries the original OEM part number. TransTec #28354 (OEM #4058487AB) will be added to all TransTec kits as stock arrives, approximate date code of M00 or later.

Illustration A

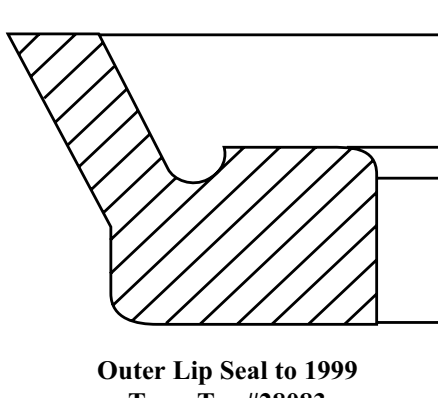

Outer Lip Seal to 1999
TransTec #28083

Illustration B

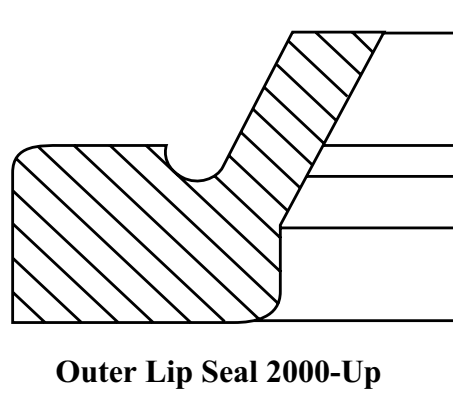

Outer Lip Seal 2000-Up
TransTec #28354