

Transtech Bulletin

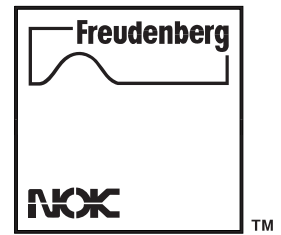

Application: General Motors

Subject: 4T80E 1993-Up Forward Clutch Inner Seal

General Motors has revised the forward clutch piston for the 4T80E beginning with the 2000 production model year. The new piston no longer takes a lip seal at the inner location. It now requires a lathe cut seal.

Care must be taken to ensure the correct seal is installed on the proper piston: If the lathe cut seal is used in an early piston, it will not protrude out of the groove far enough to make a positive seal. If the early lip seal is used in the late piston, it will not sit back in the groove far enough to install in the drum.

The new lathe cut seal is in kits with a date code of E01 and later under TransTec #23504 and OEM#24214003. the outer lip seal remains unchanged.

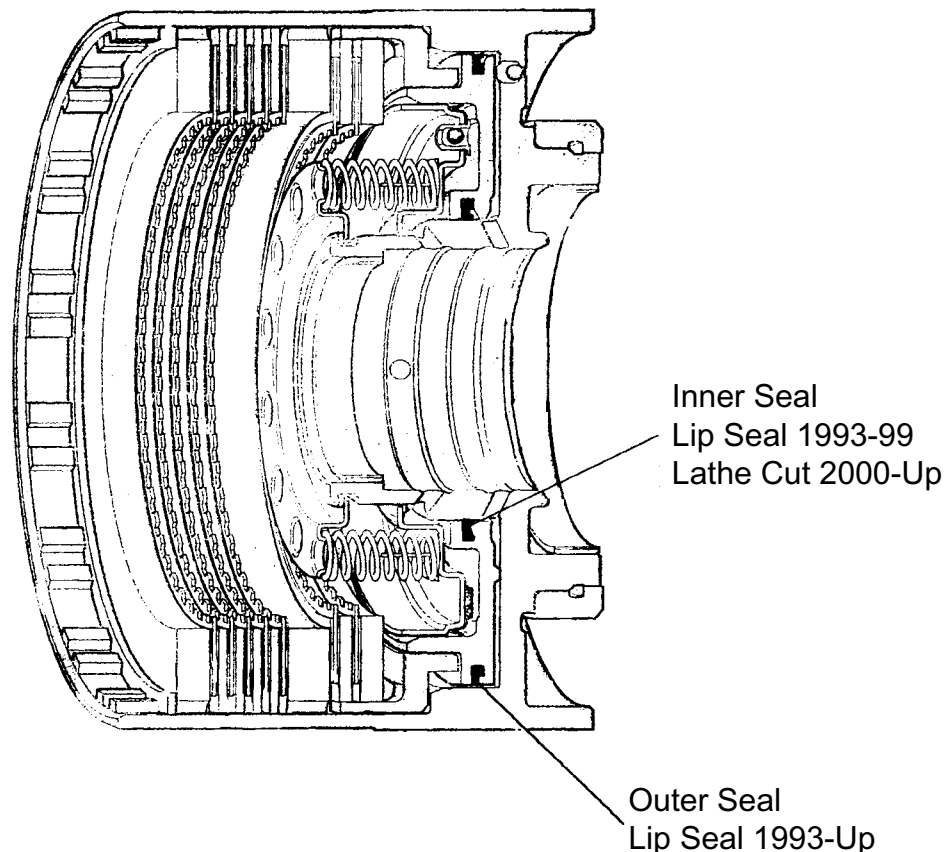

TB 6 4/2001

Visit our website at www.transtec.com

Freudenberg-NOK General Partnership
Aftermarket Division

11617 State Route 13
Milan, Ohio 44846 USA

419/499-2502
FAX 419/499-3337